

NOTES: See Tabulated Sheet

- 1 Step bore. A2 shaft may enter flexure area during operation.

Maximum shaft penetration:
A1 bore - .390in
- 2 Hubs and HELI-CAL FLEXURE are made from a single piece of material.
- 3 Integral Clamp attachment, hex. socket, cap screw furnished: both hubs.
- 4 Backlash: None.
No lubrication required.
- 5 Permitted axial motion from free length: ± .150in
- 6 Working torque ratings are based upon continuous duty with noted misalignments applied separately and may be increased with improved alignment:
See Tabulated Sheet
- 7 Permissible shaft misalignment:
Angular, up to 30 degrees.
Offset, up to .050in (TIR, .100in)
- 8 Part will have a 1.146in Clearance Diameter on both ends when any bore is over .407in thru .563in.

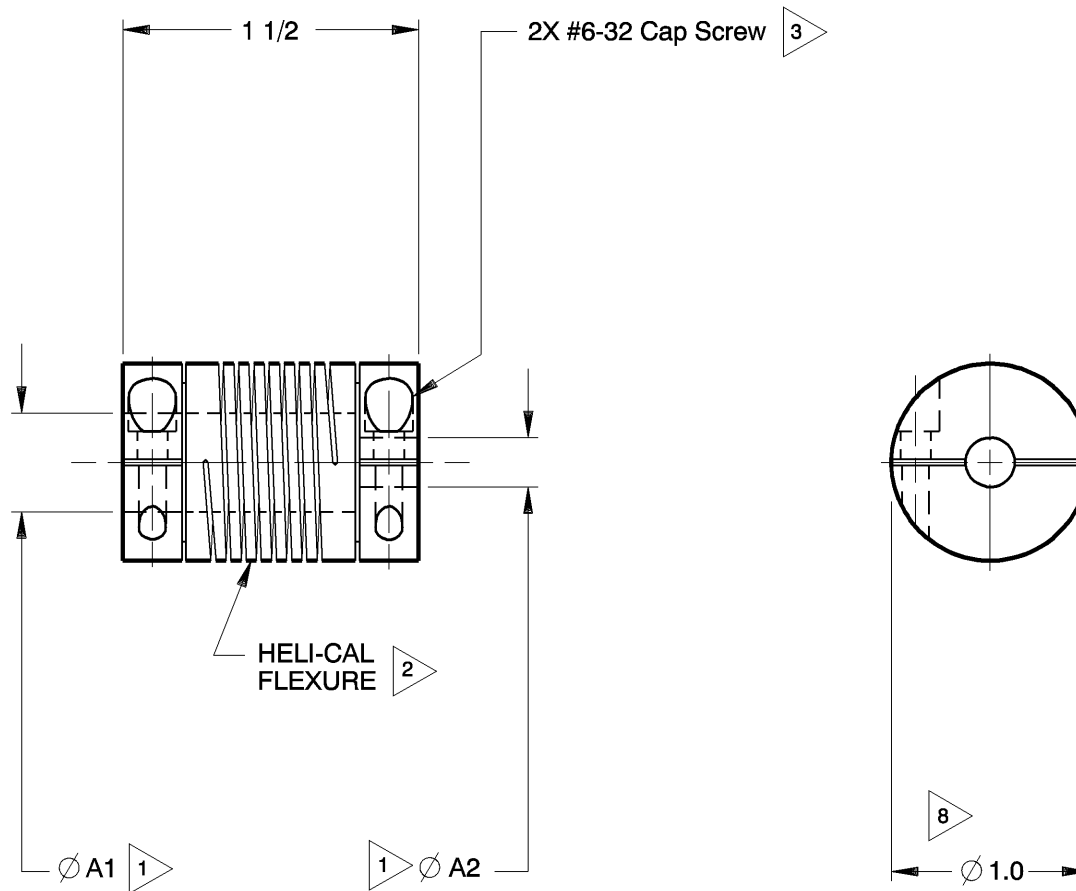

9603-16-8 SHOWN

NOTICE: THE INFORMATION AND DATA CONTAINED HEREIN IS CONSIDERED PROPRIETARY TO HELICAL PRODUCTS COMPANY, INC., AND SHALL REMAIN THE EXCLUSIVE PROPERTY OF HELICAL. THE HOLDER WILL ASSUME CUSTODY AND CONTROL THAT THIS DOCUMENT WILL NOT BE COPIED, REPRODUCED OR DISCLOSED WITHOUT THE EXPRESS WRITTEN CONSENT OF HELICAL. POSSESSION OF THIS DOCUMENT DOES NOT CONSTITUTE A GRANT TO MANUFACTURE ANY ITEMS.

DO NOT SCALE DRAWING.

02-22-10	A	Revised ECR#09121602 JAJ	HG
DATE	LTR	REVISION	CHK

Unless otherwise noted dimensions in inches.

Tolerances are:
Fractions: ± 1/64
Decimals: .XX ± .010
.XXX ± .005
.XXX ± .0010
Angles: ± 2 degrees
Break sharp corners .010 max.

APPROVALS	DATE
DRAWN BJM	11-3-97
CHECKED	
PRODN	
ISSUED	
WEIGHT	37.2g (calc)
SCALE 1/1	SIZE A

HELICAL PRODUCTS CO., INC. P.O. BOX 1069 SANTA MARIA, CA. 93456 U.S.A PHONE (805) 928-3851 FSC13201	
TITLE	HELICAL FLEXURED "U" JOINT
MATERIAL	7075-T6 Aluminum Alloy
FINISH	Anodize per HPS1000
DWG NO	9603
REV	A

ADDITION DATE	PART NUMBER	BORE TOLERANCES		TORQUES (lbin)			TORSIONAL FLEXIBILITY	MASS MOMENT OF INERTIA	COMMENTS	
		+.002in or +0.05mm -.000in 0		Non-reversing	Shock or Reversing	Momentary			A1	A2
		∅A1	∅A2							
3 NOV 97	9603-16-8	.500in	.250in	7.6	3.8	15				

NOTICE: THE INFORMATION AND DATA CONTAINED HEREIN IS CONSIDERED PROPRIETARY TO HELICAL PRODUCTS COMPANY, INC., AND SHALL REMAIN THE EXCLUSIVE PROPERTY OF HELICAL. THE HOLDER WILL ASSUME CUSTODY AND CONTROL THAT THIS DOCUMENT WILL NOT BE COPIED, REPRODUCED OR DISCLOSED WITHOUT THE EXPRESS WRITTEN CONSENT OF HELICAL. POSSESSION OF THIS DOCUMENT DOES NOT CONSTITUTE A GRANT TO MANUFACTURE ANY ITEMS.

APPROVALS	DATE	HELICAL PRODUCTS CO. INC P.O. BOX 1069 SANTA MARIA, CA. 93456 U.S.A PHONE (805) 928-3851 FSCI3201	
DRAWN BJM	11-3-97		
CHECKED			TITLE HELICAL FLEXURED "U" JOINT
PRODN			TABULATED BORE SIZES
ISSUED			DWG NO 9603 REV A