

NEW

TEMPOSONICS stroke control

- measuring via magnetostrictive sensors
- measuring accuracy < 0,1 mm
- safe and consistent settings
- no wear, no maintenance
- no pre-settings of cams necessary

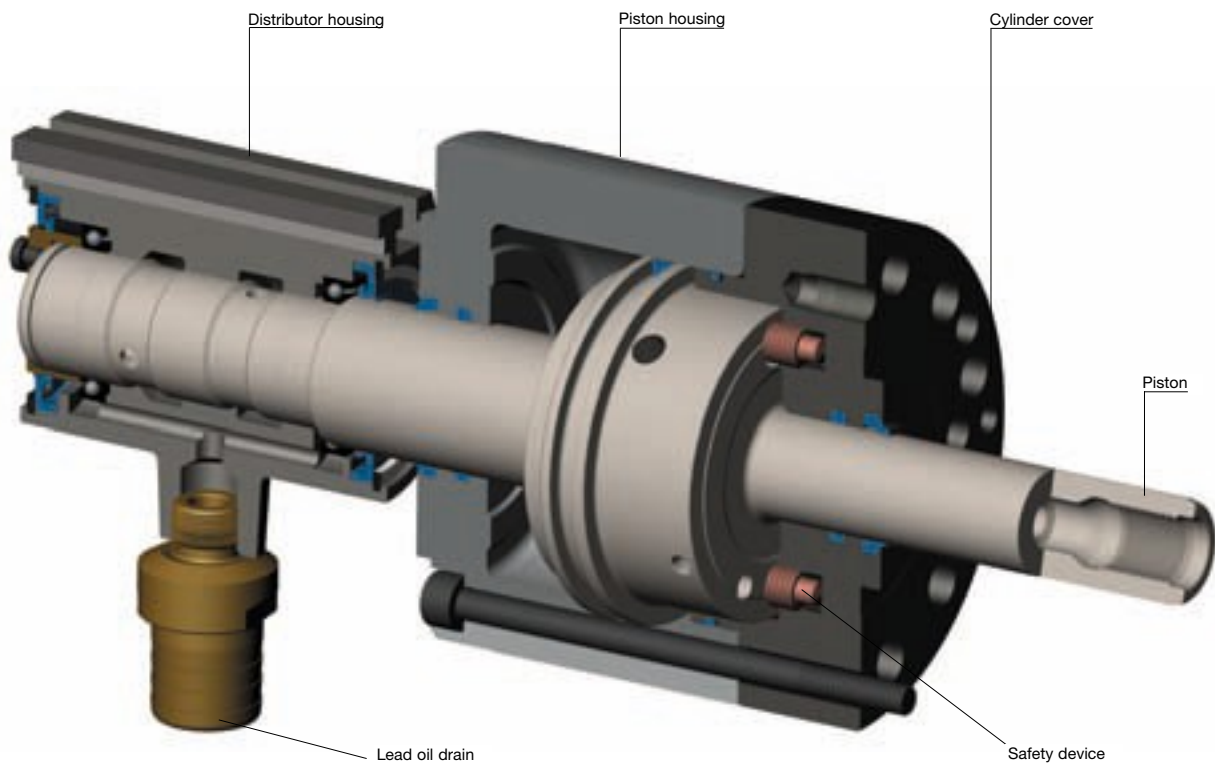

Oil operated actuating cylinders without through-hole OVS, available as basic model in **steel- or aluminium design**, also available with following **options**:

- with magnetostrictive position sensors
- with laser tracer
- with stroke monitoring by inductive proximity switches
- with analog position sensor

Suitable for horizontal or vertical installation. Compact design, low mass moment of inertia, minimum leakage.

Additional connection for auxiliary functions, such as pneumatic contact monitoring, coolant supply, central lubrication etc., further rotating unions depending on operating condition on request.

OV – closed center cylinders without safety device, without stroke monitor.

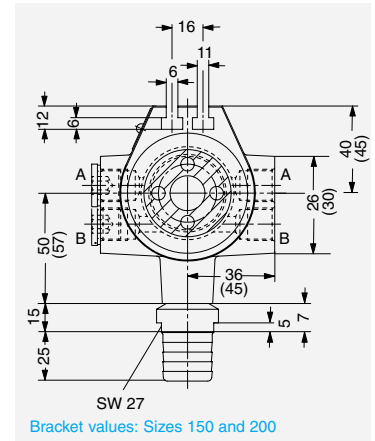
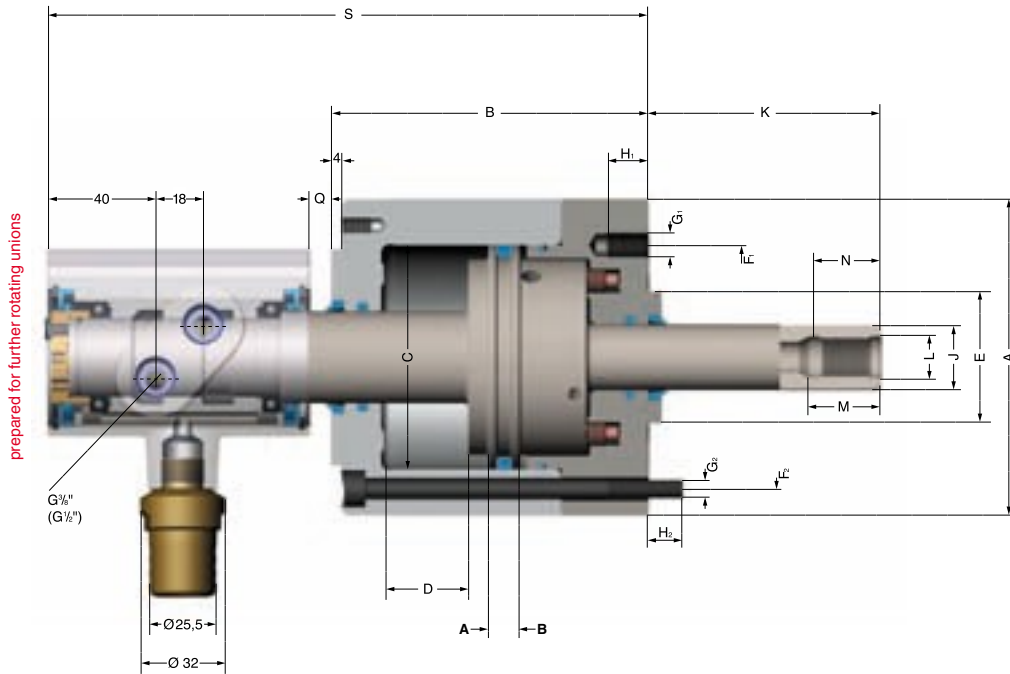

Type 452-05 Basic model – Aluminium design

for high speeds, mounting from the rear, with central passage
 Ø 6,4 mm for air, oil (central lubrication) or coolant, with safety device, **up to 40 bar**

Size	85	105	130	150	200	
Id.-No. Aluminium design	429500	429501	429502	429503	429504	
	A	120	140	165	193	245
	B	120	120	120	147	164
	C	85	105	130	150	200
	D stroke	32	32	32	45	50
	E _{h6}	50	50	80	95	125
	F ₁	80	80	105	145	170
	F ₂	100	120	145	170	220
	G ₁	3 x M 10	3 x M 10	4 x M 12	4 x M 16	6 x M 16
	G ₂	3 x M 8	3 x M 8	8 x M 8	8 x M 10	8 x M 12
	H ₁	15	15	18	24	24
	H ₂	13	13	13	13	18
	J	25	25	35	35	44
	K max.	88	88	82	98	108
	min.	56	56	50	53	58
	L	M 16	M 16	M 24	M 24	M 30
	M	35	35	50	50	60
Min. reach of draw bar	N	28	28	43	43	53
	Q max.	40	40	40	53	58
	min.	8	8	8	8	8
	S max.	252	252	252	307	329
	min.	220	220	220	262	279
Piston area	A cm ²	47,1	77	123,1	160,8	298,2
	B cm ²	51,8	81,7	123,1	167,1	299
Eff. draw bar pull (F = 30 bar)	kN	15	24	36	49,5	89
Max. permissible speed	min ⁻¹	8000	8000	6300	5500	4500
Volume for full double stroke	l	0,32	0,51	0,79	1,48	3,0
Moment of inertia J	kgm ²	0,008	0,010	0,032	0,06	0,10
Weight approx.	kg	6,7	8,4	11,7	18,4	33,2

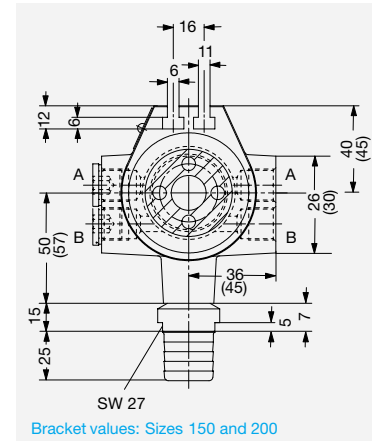
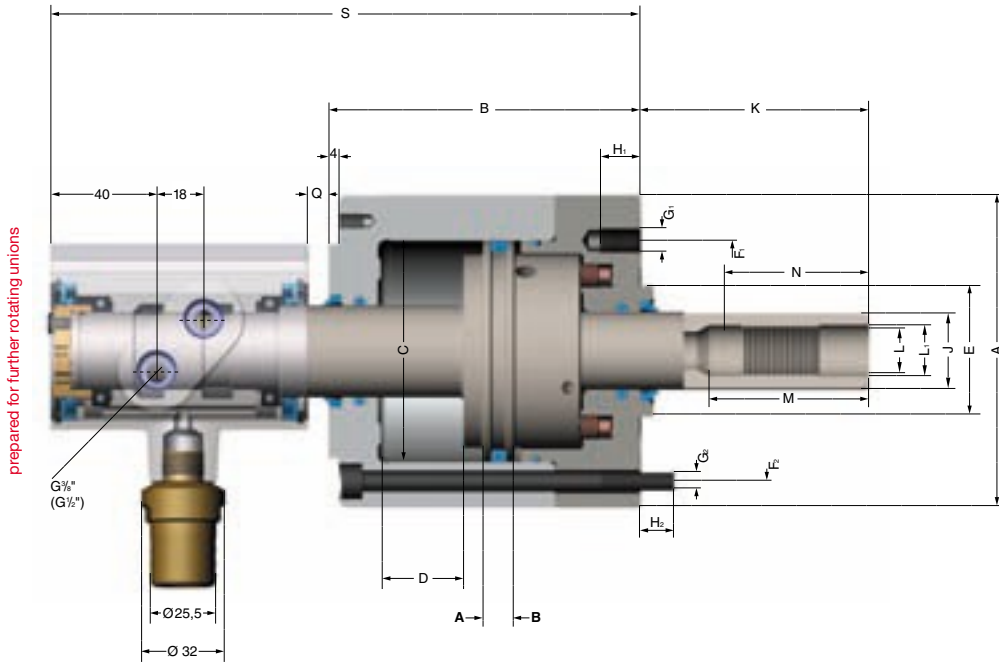

Type 453-05 Basic model – Steel design

for high speeds, mounting from the rear, with central passage
 Ø 6,4 mm for air, oil (central lubrication) or coolant, with safety device, up to 80 bar

Size	85	105	130	150	200	
Id.-No. Steel design	429505	429506	429507	429508	429509	
A	120	140	165	193	245	
B	120	120	120	147	164	
C	85	105	130	150	200	
D stroke	32	32	32	45	50	
E _{h6}	50	50	80	95	125	
F ₁	80	80	105	145	170	
F ₂	100	120	145	170	220	
G ₁	3 x M 10	6 x M 10	4 x M 12	4 x M 16	6 x M 16	
G ₂	3 x M 8	6 x M 8	8 x M 8	8 x M 10	8 x M 12	
H ₁	15	15	18	24	24	
H ₂	13	13	13	13	18	
J	30	32	42	50	70	
K max.	88	88	82	98	108	
min.	56	56	50	53	58	
L	M 20 x 1,5	M 22 x 1,5	M 30 x 2	M 36 x 2	M 48 x 2	
L ₁ ^{H8}	20,5	22,5	32	38	50	
M	65	65	77	85	105	
Min. reach of draw bar						
N	58	58	70	78	98	
Q max.	40	40	40	53	58	
min.	8	8	8	8	8	
S max.	252	252	252	307	329	
min.	220	220	220	262	279	
Piston area						
A cm ²	47,1	77	123,1	160,8	298,2	
B cm ²	49,7	78,6	118,9	157	275,7	
Eff. draw bar pull (F = 60 bar)	kN	29,5	47	71	94	165
Max. permissible speed	min ⁻¹	8000	8000	6300	5500	4500
Volume for full double stroke	l	0,31	0,5	0,775	1,43	2,87
Moment of inertia J	kgm ²	0,018	0,03	0,066	0,142	0,36
Weight approx.	kg	10	12,7	17,7	31,4	49

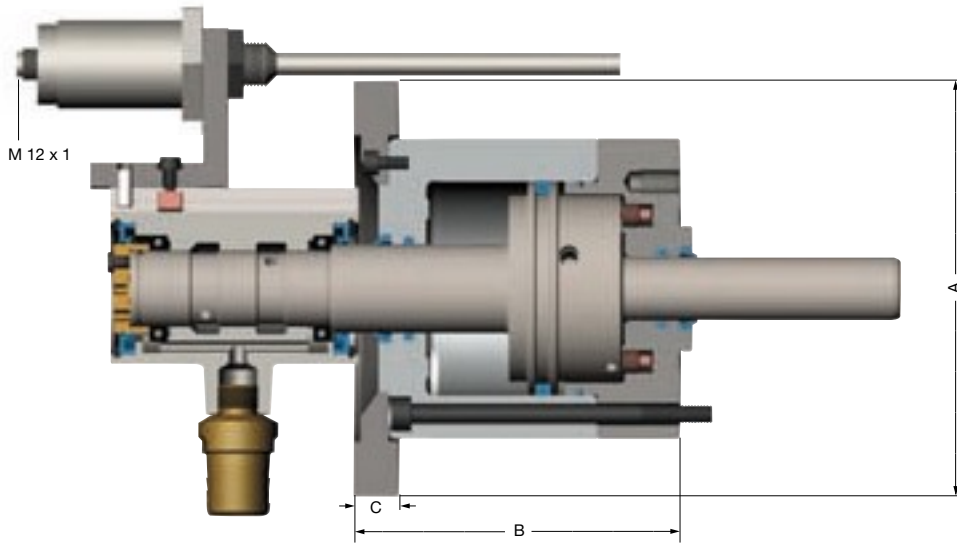
OVS Oil operated actuating cylinders without through-hole with magnetostrictive position sensors

The **magnetostrictive position sensors** uses different magnetic mechanical effects for the monitoring of length or stroke. These types of position sensors are supplied with analog, digital or field bus terminals.

Size		85	105	130	150	200
Id.-No. Aluminium design	Type 452-09	429510	429511	429512	429513	429514
Id.-No. Steel design	Type 453-09	429515	429516	429517	429518	429519
deviating dimensions from basic model	A	166	186	211	239	291
	B	130	130	130	157	174
	C	18	18	18	18	18

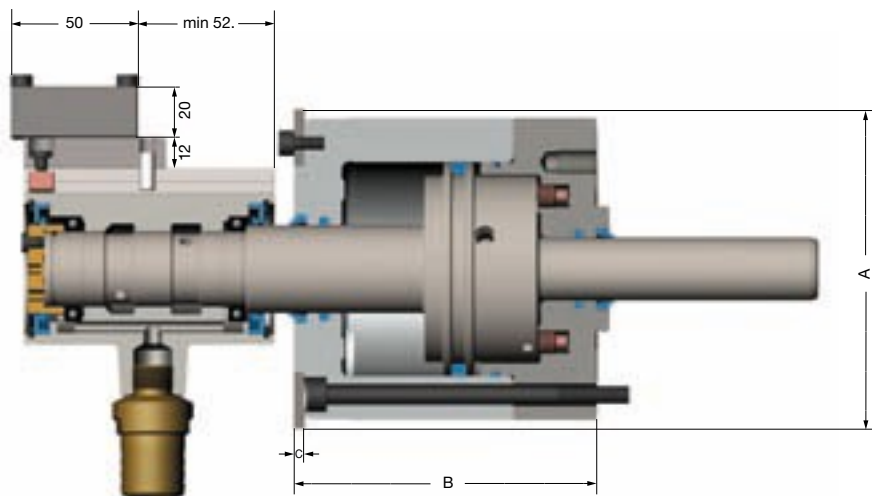
OVS Oil operated actuating cylinders without through-hole with laser tracer

The output voltage of the **laser tracer** may vary between 0 and 10 V and is proportional to the distance of the controlled object.

Size		85	105	130	150	200
Id.-No. Aluminium design	Type 452-19	429520	429521	429522	429523	429524
Id.-No. Steel design	Type 453-19	429525	429526	429527	429528	429529
deviating dimensions from basic model	A	135	155	180	208	260
	B	120	120	120	147	164
	C	4	4	4	4	4

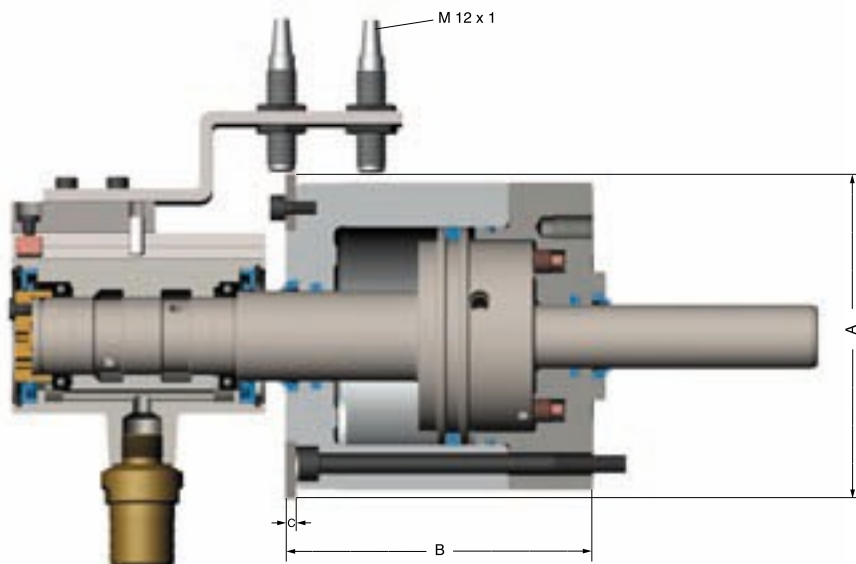
OVS Oil operated actuating cylinders without through-hole with stroke monitoring by inductive proximity switches

Two fixed control points may be monitored with **inductive proximity switches**.

Size		85	105	130	150	200	
Id.-No. Aluminium design	Type 452-29	429530	429531	429532	429533	429534	
Id.-No. Steel design	Type 453-29	429535	429536	429537	429538	429539	
deviating dimensions from basic mode		A	135	155	180	208	260
		B	120	120	120	147	164
		C	4	4	4	4	4

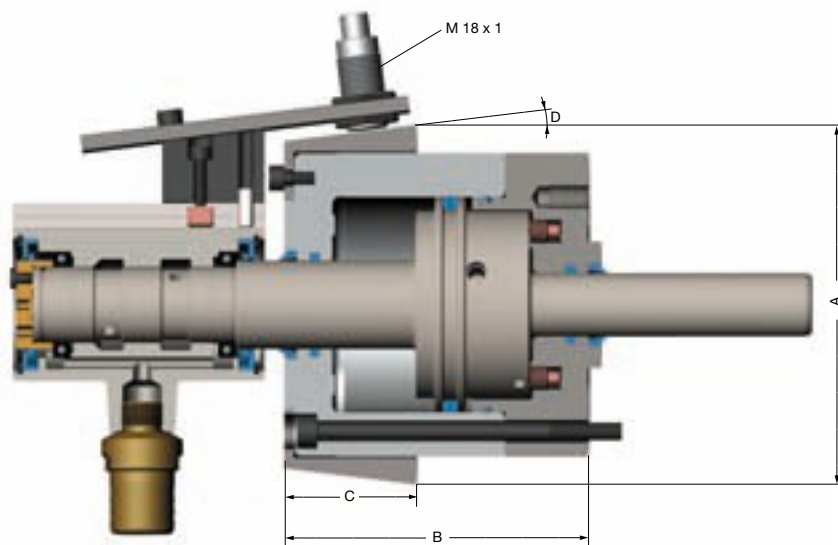
OVS Oil operated actuating cylinders without through-hole with analog position sensor

Analog position sensors supply a electrical signal which is proportional to the distance of the checked surface.

Size		85	105	130	150	200	
Id.-No. Aluminium design	Type 452-39	429540	429541	429542	429543	429544	
Id.-No. Steel design	Type 453-39	429545	429546	429547	429548	429549	
deviating dimensions from basic model		A	145	165	180	218	270
		B	120	120	120	147	164
		C	52	52	52	65	70
		D	7°	7°	7°	5°	5°

Hydraulic actuating cylinders OVS without through-hole with position sensing system for stroke control

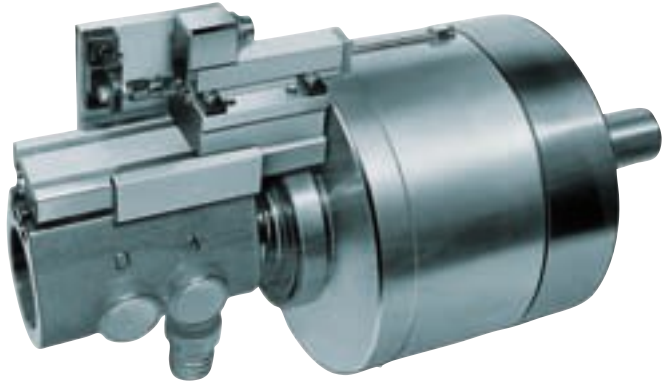

The safety regulations of the German Employer's Liability Insurance Association require that the piston stroke of actuating cylinders be monitored.

With the known stroke monitoring systems the stroke control must be adjusted to the new condition, when the clamping device has been changed.

The new systems use either

- a linear potentiometer
- an angular position transducer, or an transsonar position sensing system

both supplying analog absolute signals.

The new system, developed by Röhm, uses a linear potentiometer which means that an electric signal (variable voltage) referred to the initial point is produced for each piston position. This results in a stepless stroke monitoring and more efficient surveillance of the total piston stroke.

The angular position transducer transforms the linear stroke of piston in a rotary motion of a shaft with code disc. Scanning is effected by means of luminous diodes and photo-transistors. According to the code, disc speed changes or stops can be effected. Stepless stroke monitoring and control of the total piston stroke is possible.

The analog signals are processed by means of appropriate electronic modules and integrated into the machine control (starting interlock, handling system etc.).

The stroke can also be digitally displayed via an LED.

In this case, an analog-to-digital converter must be added to the control circuit.

This innovative measuring system has the advantage that the initial and final points can be "trimmed" or defined as desired.

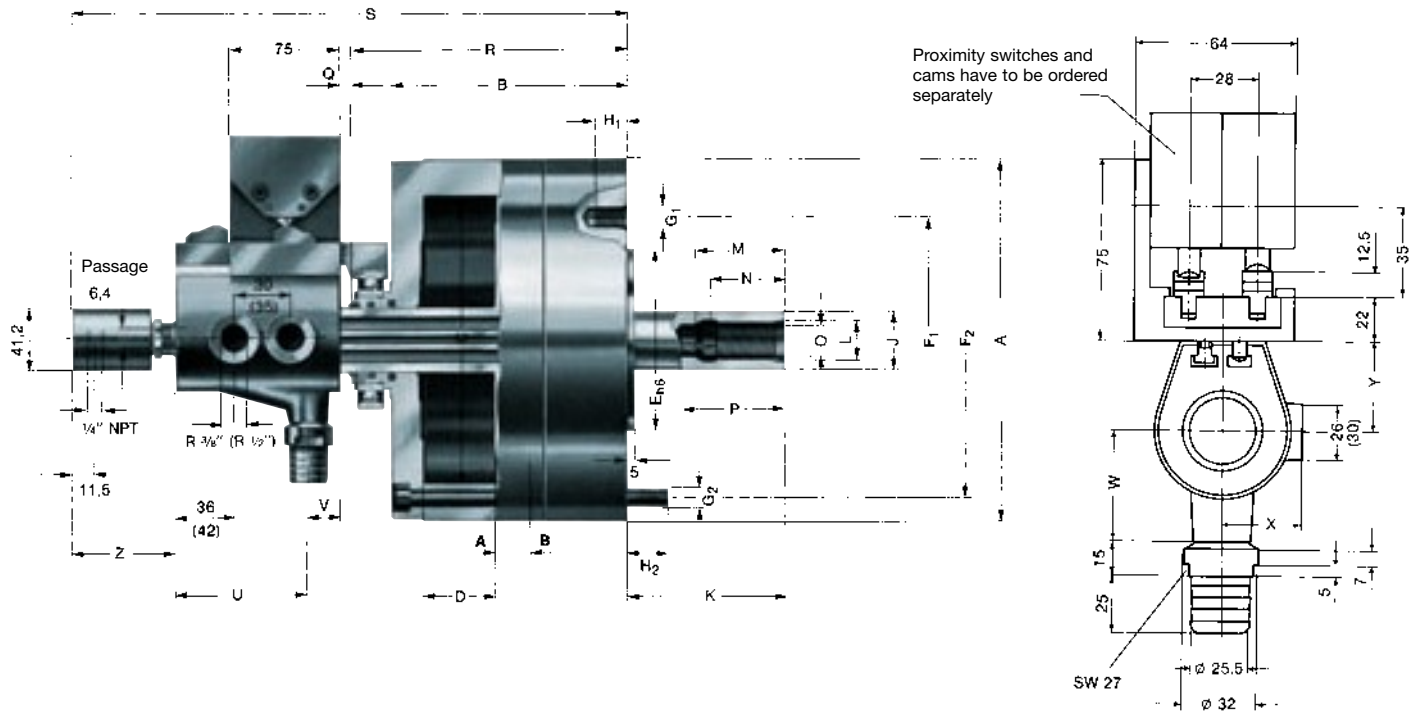
Type 452-35 for high speeds, additional mounting from the rear

Size		85	105	130	150	200
Type 452-35	without proximity switch and cams	607035	607036	607037	607038	607039
	ld.-No.					
	A	120	140	165	193	245
	B	120	120	120	144	159
	C	85	105	130	150	200
	D stroke	32	32	32	45	50
	E _{h6}	50	50	80	95	125
	F ₁	80	80	105	145	170
	F ₂	100	120	145	170	220
	G ₁	3 x M 10	3 x M 10	4 x M 12	4 x M 16	6 x M 16
	G ₂	3 x M 8	3 x M 8	8 x M 8	8 x M 10	8 x M 12
	H ₁	15	15	18	24	24
	H ₂	13	13	13	16	23
	J	25	25	35	35	44
	K	max. 88 min. 56	max. 88 min. 56	max. 82 min. 50	max. 98 min. 53	max. 108 min. 58
	L	M 16	M 16	M 24	M 24	M 30
	M	31	31	45	45	60
Min. reach of draw bar	N	26	26	39	39	53
	O ^{H8}	12	12	18	18	24
	P	40	40	60	60	80
	Q	max. 40 min. 8	max. 40 min. 8	max. 40 min. 8	max. 53 min. 8	max. 58 min. 8
	R	145	145	147	171	186
	S	max. 347 min. 315	max. 347 min. 315	max. 359 min. 327	max. 410 min. 365	max. 430 min. 380
	U	78	78	77	92	92
	V	21	21	22	22	22
	W	50	50	53	57	57
	X	36	36	41	45	45
	Y	40	40	45	45	45
	Z	63	63	73	72	72
Piston area	A cm ²	47,1	77	116,8	160,8	298,2
	B cm ²	51,8	81,7	123,1	167,1	299
Eff. draw bar pull (F = 30 bar)	daN	1500	2400	3600	4950	8900
Max. permissible speed	min ⁻¹	8000	8000	6300	5500	4500
Volume for full double stroke	l	0,32	0,51	0,77	1,48	3,0
Moment of inertia J	kgm ²	0,008	0,010	0,032	0,06	0,10
Weight approx.	kg	10,3	12	15,3	21,8	35,3

Matching chuck sizes page 296

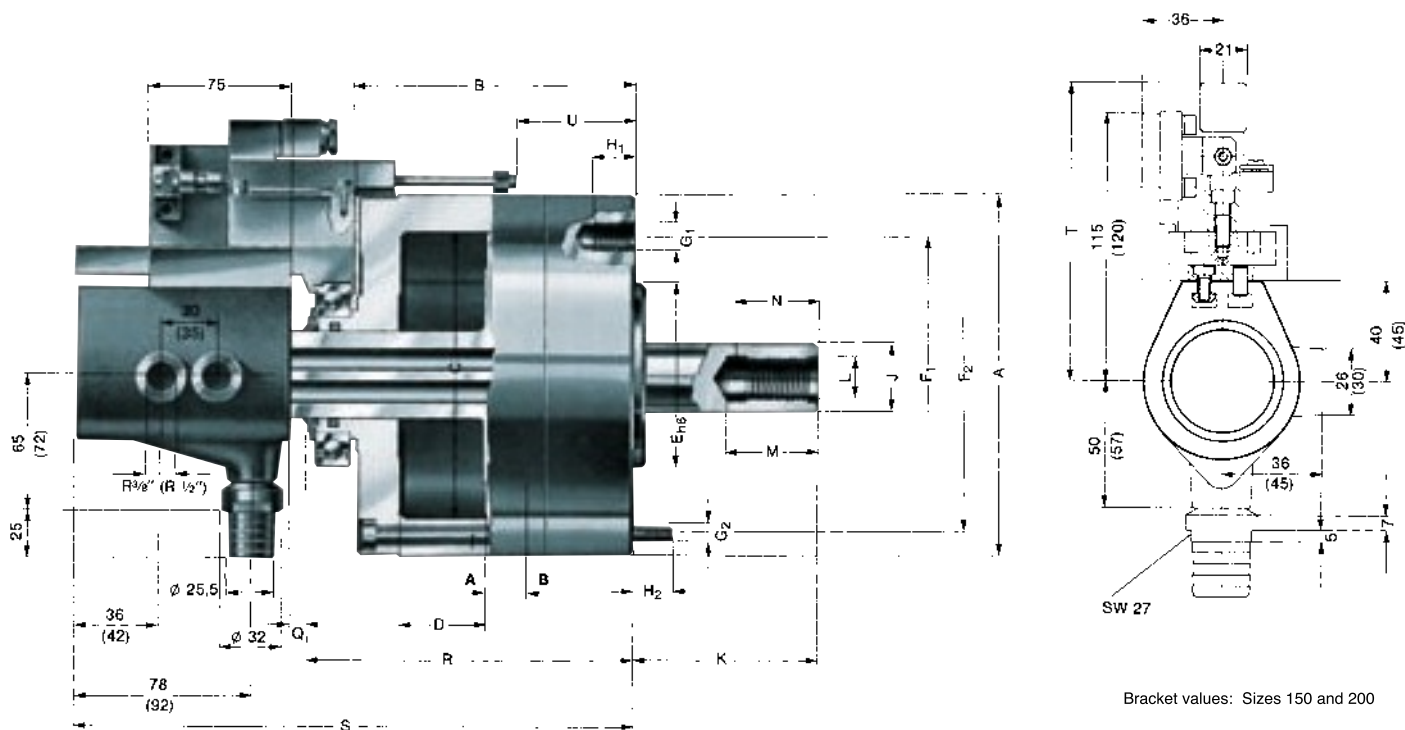

Bracket values: Sizes 150 and 200

Type 452-28 for high speeds, additional mounting from the rear

Size		85	105	130	150	200
Type 452-28	Id.-No.	415661	415662	415663	415664	415665
With high and low pressure chucking the change-over of the safety valve is guaranteed when	A	120	140	165	193	245
chucking pressure : releasing pressure $\leq 5,5 : 1$ (Size 85-130)	B	120	120	120	144	159
chucking pressure : releasing pressure $\leq 3,8 : 1$ (Size 150-200)	C	85	105	130	150	200
	D stroke	32	32	32	45	50
	E _{h6}	50	50	80	95	125
	F ₁	80	80	105	145	170
	F ₂	100	120	145	170	220
	G ₁	3 x M 10	3 x M 10	4 x M 12	4 x M 16	6 x M 16
	G ₂	3 x M 8	3 x M 8	8 x M 8	8 x M 10	8 x M 12
	H ₁	15	15	18	24	24
	H ₂	13	13	13	16	23
	J	25	25	35	35	44
	K	max. 88 min. 56	max. 88 min. 56	max. 82 min. 50	max. 98 min. 53	max. 108 min. 58
	L	M 16	M 16	M 24	M 24	M 30
	M	35	35	50	50	60
Min. reach of draw bar	N	28	28	43	43	53
	Q	max. 40 min. 8	max. 40 min. 8	max. 40 min. 8	max. 53 min. 8	max. 58 min. 8
	R	145	145	145	171	186
	S	max. 284 min. 252	max. 284 min. 252	max. 284 min. 252	max. 338 min. 293	max. 358 min. 308
	T	115	120	130	140	166
	U	min. 35	min. 35	min. 35	min. 61	min. 75
Piston area	A cm ²	47,1	77	123,1	160,8	298,2
	B cm ²	51,8	81,7	123,1	167,1	301,6
Eff. draw bar pull (F = 30 bar)	daN	1500	2400	3600	4950	9000
Max. permissible speed	min ⁻¹	8000	8000	6300	5500	4500
Volume for full double stroke	l	0,32	0,51	0,79	1,48	3,0
Moment of inertia J	kgm ²	0,008	0,010	0,032	0,06	0,10
Weight approx.	kg	8,8	10,5	13,8	20,8	34,6

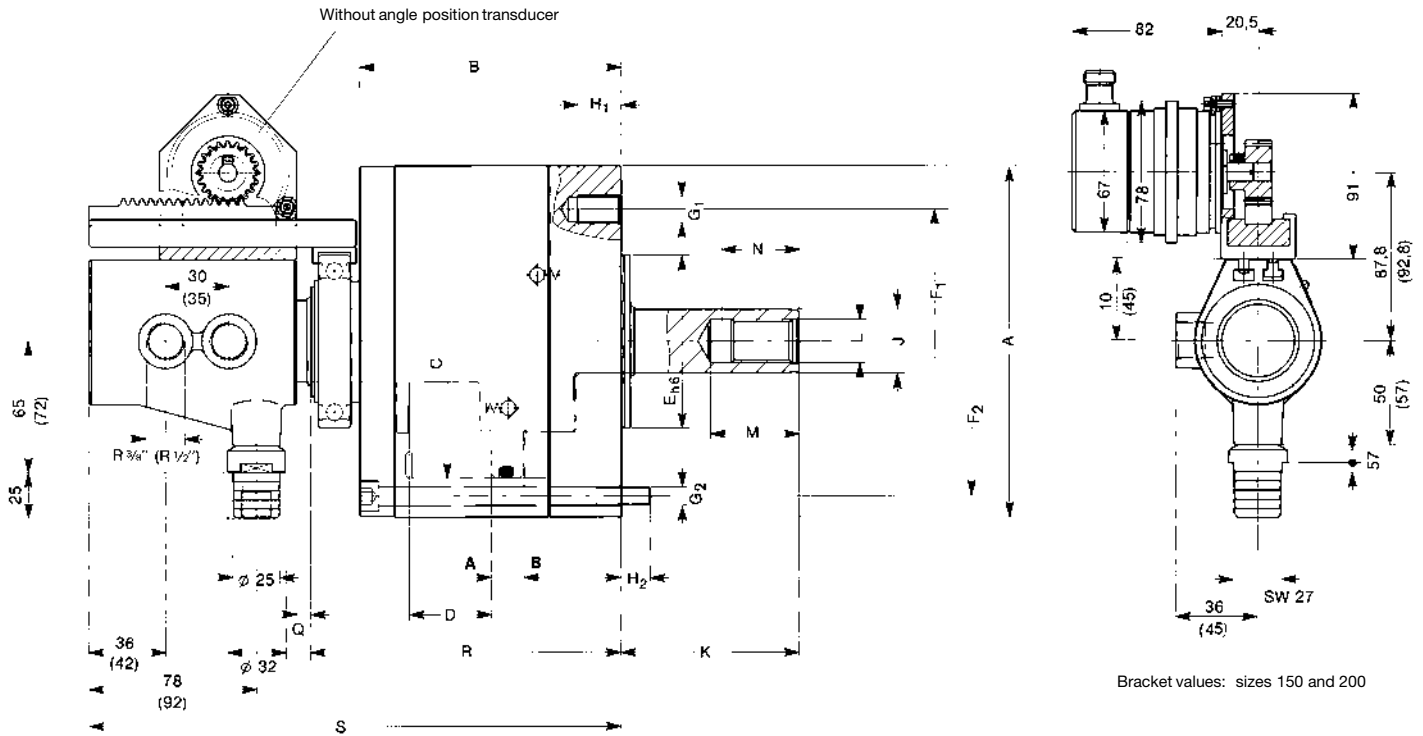

Type 452-85 for high speeds, additional mounting from the rear

Size		85	105	130	150	200	
Type 452-85	Id.-No.	418641	418642	418643	418644	418645	
	A	120	140	165	193	245	
	B	120	120	120	144	159	
	C	85	105	130	150	200	
	D stroke	32	32	32	45	50	
	E _{h6}	50	50	80	95	125	
	F ₁	80	80	105	145	170	
	F ₂	100	120	145	170	220	
	G ₁	3 x M 10	3 x M 10	4 x M 12	4 x M 16	6 x M 16	
	G ₂	3 x M 8	3 x M 8	8 x M 8	8 x M 10	8 x M 12	
	H ₁	15	15	18	24	24	
	H ₂	13	13	13	16	23	
	J	25	25	35	35	44	
	K	max.	88	88	98	108	
		min.	56	56	50	53	58
	L	M 16	M 16	M 24	M 24	M 30	
	M	35	35	50	50	60	
Min. reach of draw bar	N	28	28	43	43	53	
	Q	max.	40	40	53	58	
		min.	8	8	8	8	8
	R	145	145	145	171	186	
	S	max.	284	284	284	338	358
		min.	252	252	252	293	308
Piston area	A cm ²	47,1	77	123,1	160,8	298,2	
	B cm ²	51,8	81,7	123,1	167,1	301,6	
Eff. draw bar pull (F = 30 bar)	daN	1500	2400	3600	4950	9000	
Max. permissible speed	min ⁻¹	8000	8000	6300	5500	4500	
Volume for full double stroke	l	0,32	0,51	0,79	1,48	3,0	
Moment of inertia J	kgm ²	0,008	0,010	0,032	0,06	0,10	
Weight approx.	kg	8,8	10,5	13,8	20,8	34,6	

RÖHM GF cast adaptor plates for actuating cylinders OVS, LVS, LTS

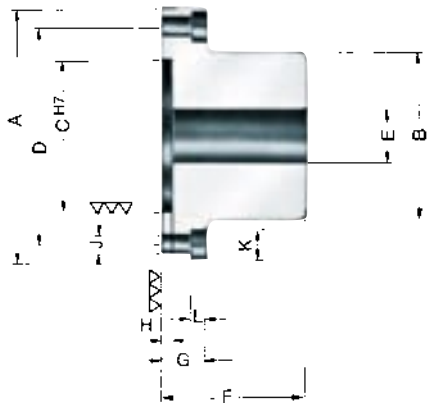

Type 552-86 = finished on cylinder side

Size	OVS	85-105	130	150	200	-
Size	LVS	85-105	130	150-200	250-350	-
Size	LTS	-	-	150-200	250	300
	Id.-No.	61528	61529	61530	61531	33541
A		100	130	175	200	240
B		60	75	115	140	160
C		50	80	95	125	140
D		80	105	145	170	200
E		30	37	42	52	52
F		130	140	140	140	140
G		20	25	26	26	26
H		6	6	6	6	6
J		11	14	18	18	18
K		18	20	26	26	26
L		10	12	16	16	16
Number of mounting bolts		3	4	4	6	6

Possible methods of mounting adaptor plates on spindle noses

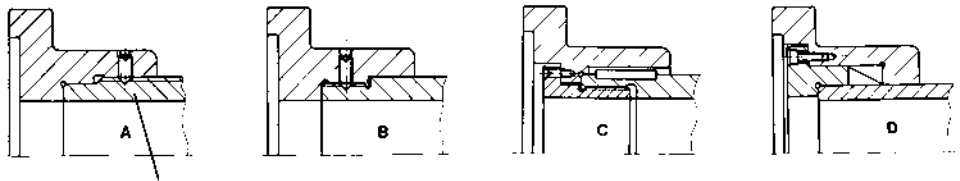

Machine spindle

Support bracket for OVS/LTS hydraulic cylinder, without through-hole, with safety-device and stroke control

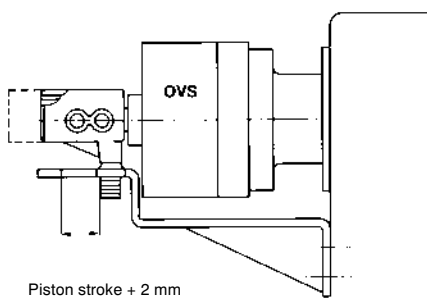

Piston stroke + 2 mm

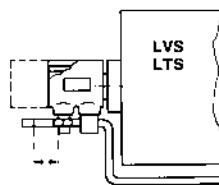

Piston stroke + 2 mm

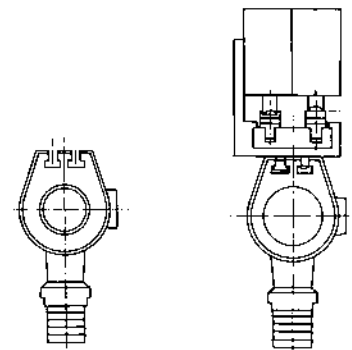

Thickness of brackets should be between 6 and 10 mm depending on the size of the cylinder.

According to the regulations of the German Employers' Liability Insurance Association rotating cylinders must be covered by a hood on the machine-side.

RÖHM Matching chuck sizes OVS, LVS, LTS

OVS Size		85	105	130	150	200			
3- and 4-jaw chucks	KFD	85-125+140	130	160	160-250	200-1600			
	KFD-HS	110	110-175	200	250	315-500			
	DURO-NC		140	160	175+2000	250-630			
	KFD-HE		160	160+200	250	315+400			

LVS Size			130	150	200	250	300	350
3- and 4-jaw chucks	KFD		85-125+140	85-125+140	130	160	200+250	250-315
	DURO-NC					160	200+250	315-600
	KFD-HE					160	200+250	300+400

LTS Size				150	200	250	300	
3- and 4-jaw chucks	KFD			130	160-250	200-315	250-400	
	DURO-NC				160+200	250		
	KFD-HE				160+200	250	315+400	

OVS Size		85	105	130	150	200		
2-jaw chucks	KFD	125-140	130+160	160+200	160-250	200-630		